

RoHS
Compatible

發行
2010.11.29
達立

△				
△				
△				
△				
ZONE	REV	DESCRIPTION	DATE	APPD.

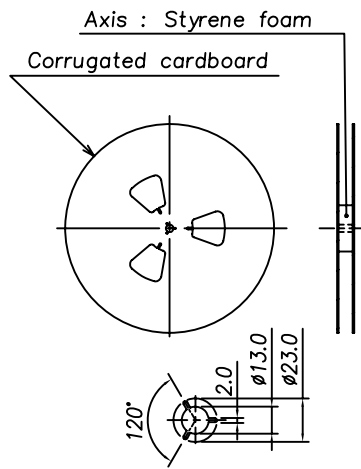
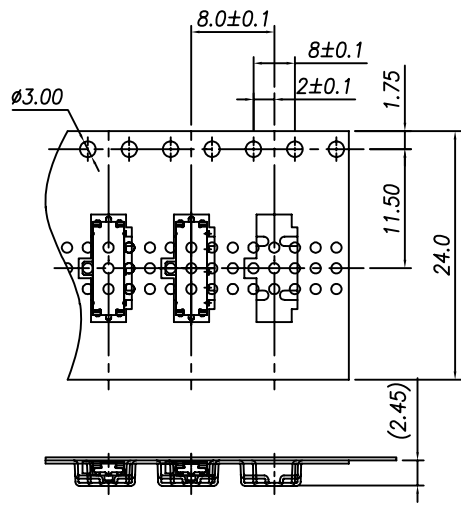
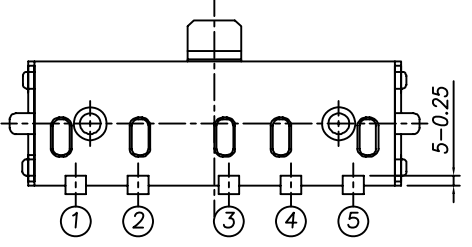
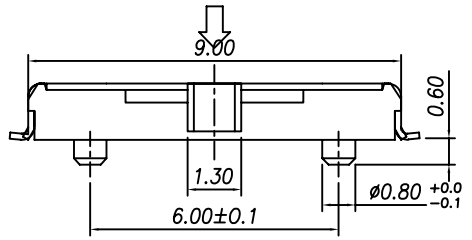
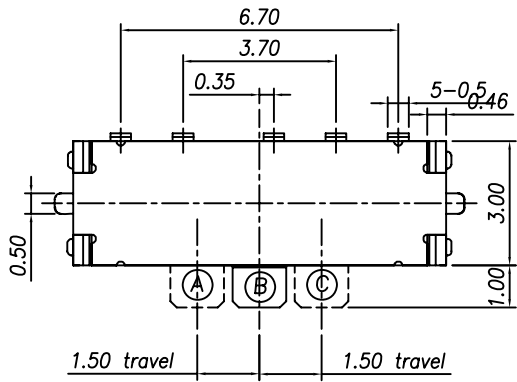
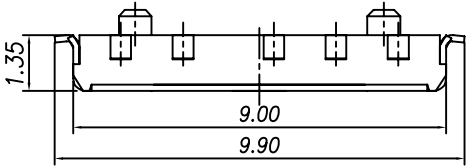

P.C.B Mounting pattern Dimension

Circuit Diagram

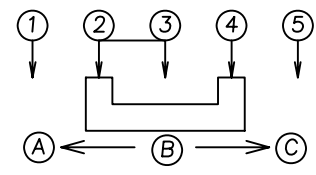
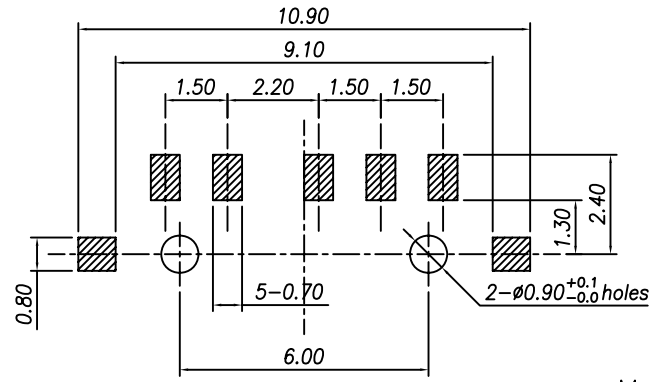

Specification

1. Rating : DC 4V 0.3A Max.
2. Contact resistance : 200mΩ Max.
3. Insulation resistance : 100MΩ Min.
4. Travel : 1.5mm
5. Operating life : 10,000 cycles
6. Operating force: 120±100g

Material

1. Case : LCP
2. Terminal : Copper alloy
3. Knob : PA
4. Cover : SUS
5. Contact : Copper alloy
6. Spring : SWP

達立科技股份有限公司
Dawning Precision Co., Ltd.
TEL: 886-2-82271388 FAX: 886-2-82272198

DESIGN	Will	SCALE		
DRAWING	Will	UNIT	mm	
CHECK	Will	SIZE	A4: 210*297	
APPROVAL	Eric	VERSION	01	

TOLERANCE UNLESS OTHERWISE STATED(mm)	PART NAME	SLIDE SWITCH
less than 10 — ±0.2	PART NO	SS-1301C-S009
10~30 — ±0.3	DRAWING NO	
30~100 — ±0.5	DATE	2010/10/25
ANGIE — ±2°		