

△				
△				
△				
△				
ZONE	REV	DESCRIPTION	DATE	APPD.

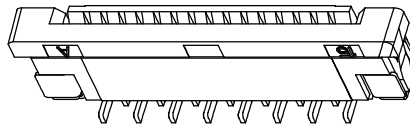

Order information :
 FP105501-XX X TO N-A-S209
 1 2 3 4 5



- Pin No. = 04~40
- Packing :
0 = Tape & Reel with CAP
- Plating spec
TO = Bright Sn Plated
- Housing Color :
N = Natural
- A = Positive Pin

R&D發行
 2023.08.15
 達立

Specifications

- Voltage Rating : 50V AC/DC
- Contact resistance : 30mΩ
- Insulation resistance : 500MΩ
- Operating temperature : -25°C~+85°C

No. of contacts	Dimensions			No. of contacts	Dimensions		
	A	B	C		A	B	C
4	3.00	5.03	11.10	24	23.00	25.03	31.10
5	4.00	6.03	12.10	25	24.00	26.03	32.10
6	5.00	7.03	13.10	26	25.00	27.03	33.10
7	6.00	8.03	14.10	27	26.00	28.03	34.10
8	7.00	9.03	15.10	28	27.00	29.03	35.10
9	8.00	10.03	16.10	29	28.00	30.03	36.10
10	9.00	11.03	17.10	30	29.00	31.03	37.10
11	10.00	12.03	18.10	31	30.00	32.03	38.10
12	11.00	13.03	19.10	32	31.00	33.03	39.10
13	12.00	14.03	20.10	33	32.00	34.03	40.10
14	13.00	15.03	21.10	34	33.00	35.03	41.10
15	14.00	16.03	22.10	35	34.00	36.03	42.10
16	15.00	17.03	23.10	36	35.00	37.03	43.10
17	16.00	18.03	24.10	37	36.00	38.03	44.10
18	17.00	19.03	25.10	38	37.00	39.03	45.10
19	18.00	20.03	26.10	39	38.00	40.03	46.10
20	19.00	21.03	27.10	40	39.00	41.03	47.10
21	20.00	22.03	28.10				
22	21.00	23.03	29.10				
23	22.00	24.03	30.10				

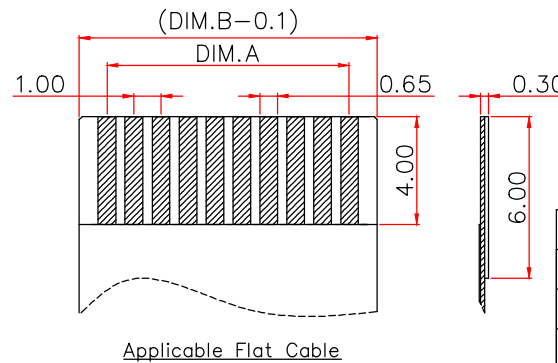
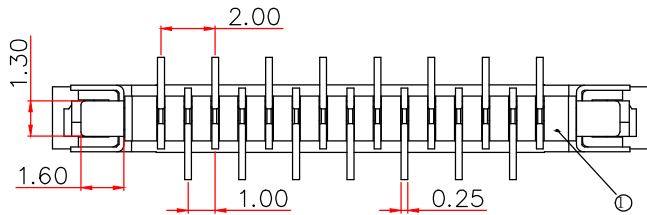
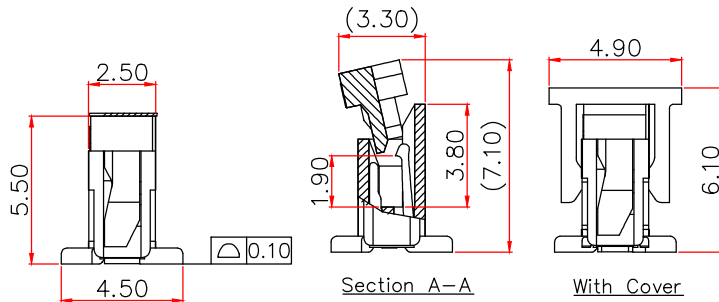
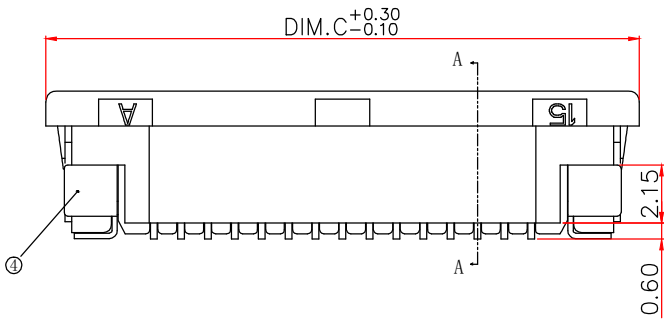
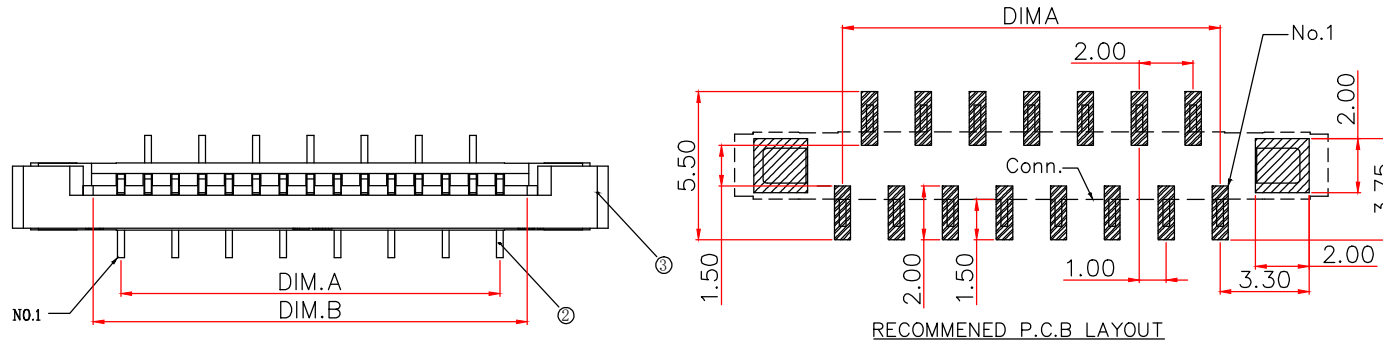

4	Terminal 2	Copper Alloy	2	Sn Plated
3	Actuator	LCP	1	Black/UL94 V-0
2	Terminal 1	Copper Alloy	XX	
1	Housing	LCP	1	Natural/UL94 V-0
No.	Part Name	Material	Qty	Finishing

達立科技股份有限公司
 Dawning Precision Co., Ltd.
 TEL: 886-2-82271388 FAX: 886-2-82272198

DESIGN	Charles	SCALE		
DRAWING	Charles	UNIT	mm	
CHECK	Charles	SIZE	A4: 210*297	
APPROVAL	Baker	VERSION	02	
TOLERANCE UNLESS OTHERWISE STATED(mm)				
0	±0.35			
0.0	±0.25			
0.00	±0.15			
ANGLE	±3°			

PART NAME	FPC 1.0mm Pitch H=5.5
PART NO	FP105501-XXXTON-A-S209
DRAWING NO	
DATE	2023/08/15

www.dawning2.com.tw