

△				
△				
△				
△				
ZONE	REV	DESCRIPTION	DATE	APPD.

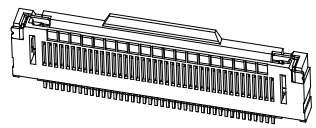

RD&發行
2023.07.21
達立

RoHS
Compatible

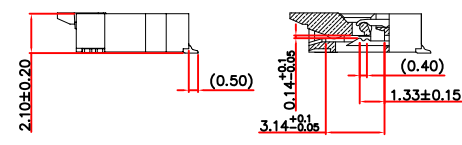
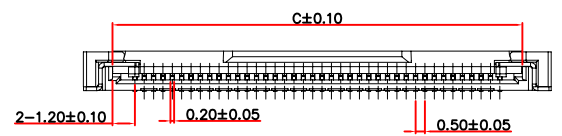
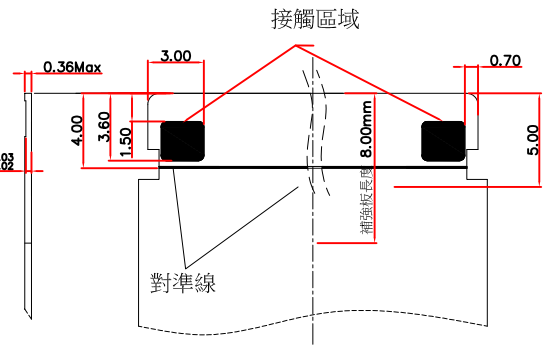
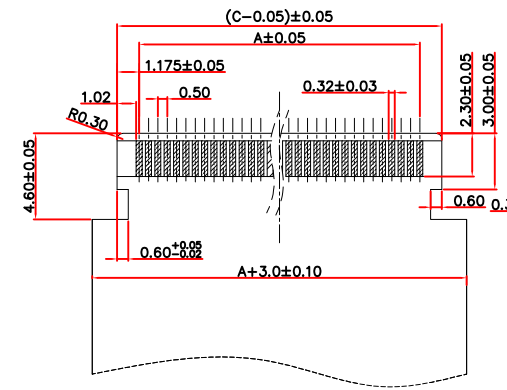
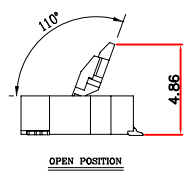
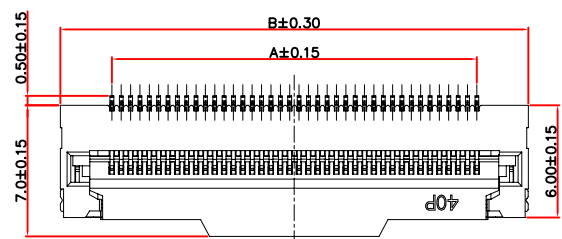

(Applicable Flat Cable)

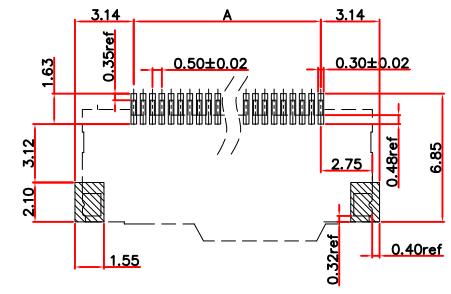
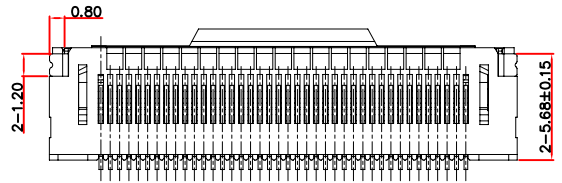

RECOMMEN P.C.B MOUNTING
(PCB TOLERANCE ±0.05)

PIN NO.	Dimensions		
	A	B	C
9	4.00	9.50	6.40
10	4.50	10.00	6.90
20	9.50	15.00	11.90
30	14.50	20.00	16.90
40	19.50	25.00	21.90
50	24.50	30.00	26.90
51	25.00	30.50	27.40

Order information :
FP052201-xx 0 S0 N-S209
1 2 3 4

- Pin No. 09~51
- Packing :
0 = Tape & Reel
- Plating spec :
S0 = Selective
- Color :
N = Nature

Specifications

- Voltage Rating : 50V AC,DC, 0.5A
- Contact resistance : 30mΩ Max.
- Insulation resistance : 100MΩ Min.
- Temperature Range : -25°C ~ +85°C

4	Peg	Copper alloy	1	Sn Plated
3	Cover	LCP ,UL94 V-0	1	Black
2	Contact	Copper alloy	1	Selective
1	Housing	LCP ,UL94 V-0	1	Natural
No.	Part Name	Material	Qty	Finishing

達立科技股份有限公司
Dawning Precision Co.,Ltd.
TEL: 886-2-82271388 FAX: 886-2-82272198

DESIGN	Jeff	SCALE		
DRAWING	Jeff	UNIT	mm	
CHECK	Jeff	SIZE	A4: 210*297	
APPROVAL	Baker	VERSION	02	

TOLERANCE UNLESS OTHERWISE STATED(mm)		PART NAME	FPC 0.5mm PITCH H=2.2mm
0	±0.50	PART NO	FP052201-xx0S0N-S209
0.0	±0.25	DRAWING NO	
0.00	±0.15	DATE	2023.07.21
ANGLE	±2°		