

|      |     |             |      |       |
|------|-----|-------------|------|-------|
| △    |     |             |      |       |
| △    |     |             |      |       |
| △    |     |             |      |       |
| △    |     |             |      |       |
| ZONE | REV | DESCRIPTION | DATE | APPD. |

**RoHS**  
**Compatible**

R&D發行  
2023.07.11  
達立

CIRCUIT DIAGRAM

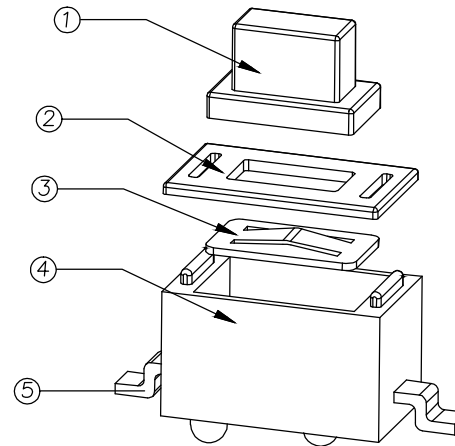
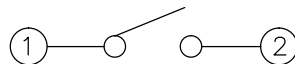
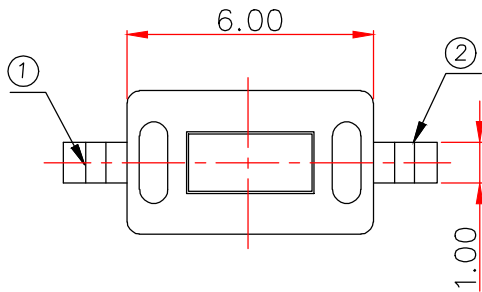

RECOMMENED P.C.B MOUNTING  
PATTERN DIMENSION

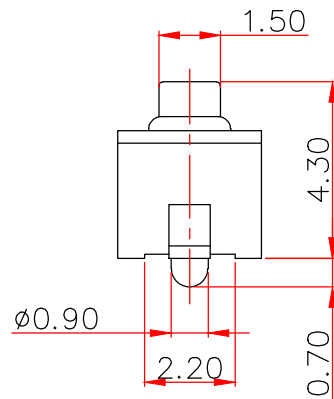
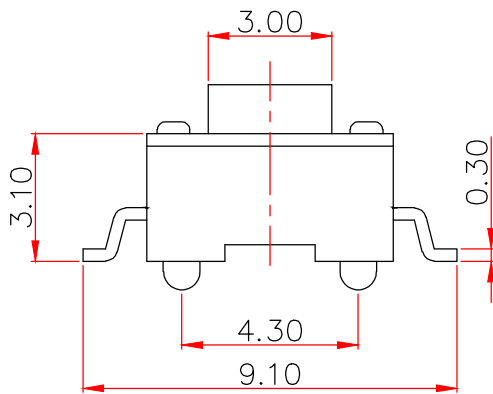
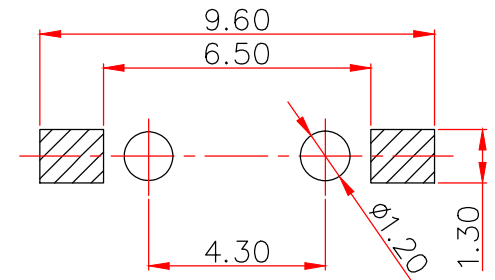

Specifications

1. Rating : DC 12V, 50mA.
2. Travel : 0.25±0.10mm
3. Contact resistance : 50mΩ Max.
4. Insulation resistance : 100MΩ Min.
5. Operating force : 160±50gf
6. Operating life : 50,000 cycles Min.

| 5   | Terminal  | Brass           | 1    | Ag Plated |
|-----|-----------|-----------------|------|-----------|
| 4   | Case      | PPA             | 1    | Black     |
| 3   | Contact   | Stainless Steel | 1    | —————     |
| 2   | Cover     | Brass           | 1    | Sn Plated |
| 1   | Stem      | PPA             | 1    | Black     |
| No. | Part Name | Material        | Q'ty | Finishing |

達立科技股份有限公司

**Dawning Precision Co.,Ltd.**

TEL: 886-2-82271388 FAX: 886-2-82272198

|          |         |         |             |  |
|----------|---------|---------|-------------|--|
| DESIGN   | Charles | SCALE   |             |  |
| DRAWING  | Charles | UNIT    | mm          |  |
| CHECK    | Charles | SIZE    | A4: 210*297 |  |
| APPROVAL | Baker   | VERSION | 01          |  |

| TOLERANCE UNLESS OTHERWISE STATED(mm) |       |
|---------------------------------------|-------|
| 0                                     | ±0.40 |
| 0.0                                   | ±0.35 |
| 0.00                                  | ±0.30 |
| ANGLE                                 | ±2°   |

|            |                 |
|------------|-----------------|
| PART NAME  | TACT SWITCH     |
| PART NO    | TS-A01SE-2-S184 |
| DRAWING NO |                 |
| DATE       | 2023/07/11      |

www.dawning2.com.tw