

RoHS
Compatible

R&D發行
2022.08.18
達立

△				
△				
△				
△				
ZONE	REV	DESCRIPTION	DATE	APPD.

RECOMMENDED P.C.B MOUNTING PATTERN DIMENSION

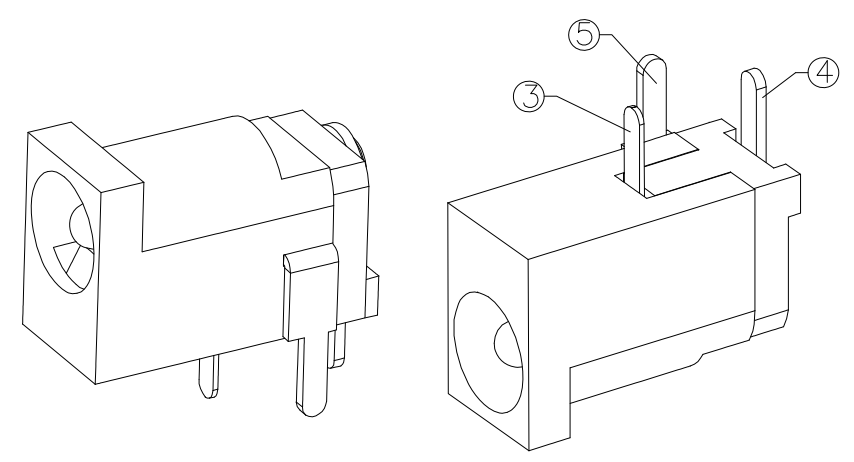
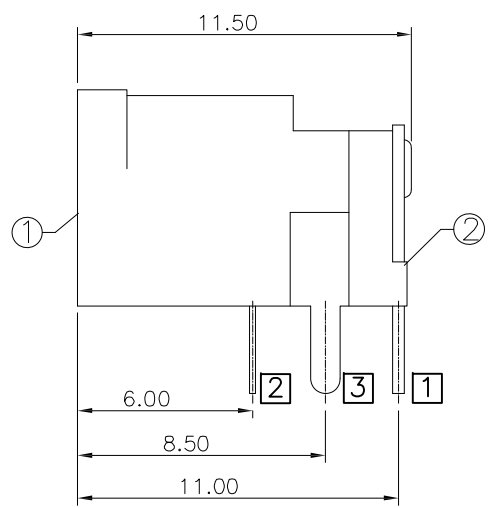
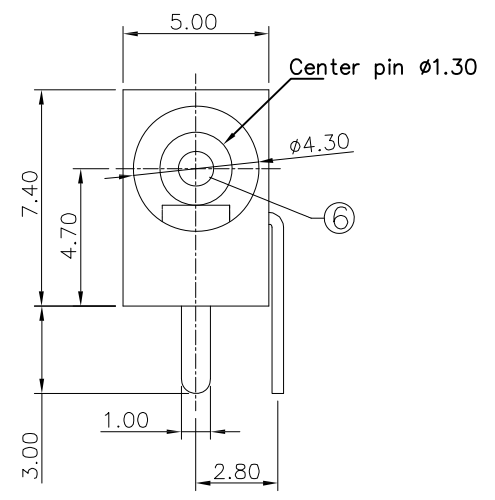
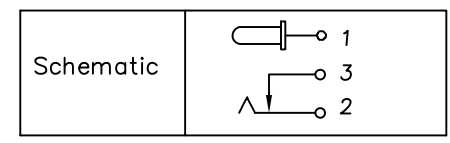
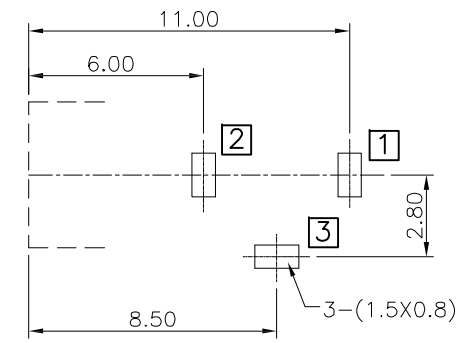

SPECIFICATIONS :

1. Rating : DC 16V, 3.5A.
2. Contact resistance : 50mΩ Max.
3. Insulation resistance : 100MΩ Min.
4. Withstand voltage : 500V AC.
5. Insertion&withdrawal force : 0.3~3.0 Kgf
6. Life : 5000 Cycles Min.

6	Pin	Brass	1	Ni Plated
5	Flat Foot	Brass	1	Ag Plated
4	Curve Piece	Brass	1	Ag Plated
3	Spring Piece	SUS	1	Ag Plated
2	Cover	PBT	1	Black
1	Housing	PBT	1	Black
No.	Part Name	Material	Q'ty	Finishing

達立科技股份有限公司
Dawning Precision Co.,Ltd.
TEL: 886-2-82271388 FAX: 886-2-82272198

DESIGN	Chung	SCALE		
DRAWING	Chung	UNIT	mm	
CHECK	Chung	SIZE	A4: 210*297	
APPROVAL	Baker	VERSION	01	

TOLERANCE UNLESS OTHERWISE STATED(mm)	PART NAME	DC POWER SOCKET
0 ——— ±0.50	PART NO	DC-009H-1-C-S243
0.0 ——— ±0.40	DRAWING NO	
0.00 ——— ±0.30	DATE	2022.08.18
ANGLE ——— ±2°		

www.dawning2.com.tw