

△				
△				
△				
△				
ZONE	REV	DESCRIPTION	DATE	APPD.

ORDER INFORMATION :
 FP10252-XX $\frac{0}{1}$ $\frac{X}{2}$ $\frac{N}{3}$ -S209

1. PIN NO.: 04~40
 2. PACKING:
 0 : TAPE & REEL
 3. PLATING
 G : GOLD FLASH
 S : Bright Sn Plated
 4. HOUSING COLOR
 N : NATURAL

RoHS
Compatible

R&D發行
 2020.10.21
 達立

Specifications
 1. Voltage Rating : 30V AC
 2. Contact resistance : 0.03Ω Max.
 3. Insulation resistance : 500MΩ Min.
 4. Temperature Range : -25°C ~ +85°C

Material
 1. Housing : LCP , UL94V-0, Natural
 2. Terminal : Copper Alloy
 3. Actuator : LCP, UL94V-0 ,Black
 4. Fitting Nail: Copper Alloy , Sn Plated

PIN NO.	Dimensions		
	A	B	C
4	3.00	5.03	11.10
5	4.00	6.03	12.10
6	5.00	7.03	13.10
7	6.00	8.03	14.10
8	7.00	9.03	15.10
9	8.00	10.03	16.10
10	9.00	11.03	17.10
11	10.00	12.03	18.10
12	11.00	13.03	19.10
13	12.00	14.03	20.10
14	13.00	15.03	21.10
15	14.00	16.03	22.10
16	15.00	17.03	23.10
17	16.00	18.03	24.10
18	17.00	19.03	25.10
19	18.00	20.03	26.10
20	19.00	21.03	27.10
21	20.00	22.03	28.10
22	21.00	23.03	29.10
23	22.00	24.03	30.10
24	23.00	25.03	31.10
25	24.00	26.03	32.10
26	25.00	27.03	33.10
27	26.00	28.03	34.10
28	27.00	29.03	35.10
29	28.00	30.03	36.10
30	29.00	31.03	37.10
31	30.00	32.03	38.10
32	31.00	33.03	39.10
33	32.00	34.03	40.10
34	33.00	35.03	41.10
35	34.00	36.03	42.10
36	35.00	37.03	43.10
37	36.00	38.03	44.10
38	37.00	39.03	45.10
39	38.00	40.03	46.10
40	39.00	41.03	47.10

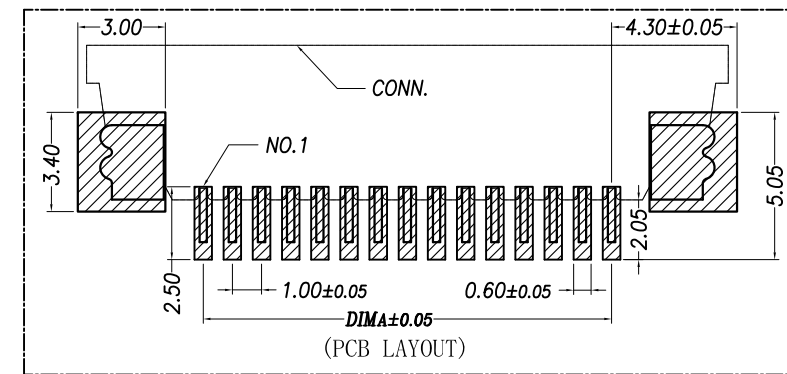
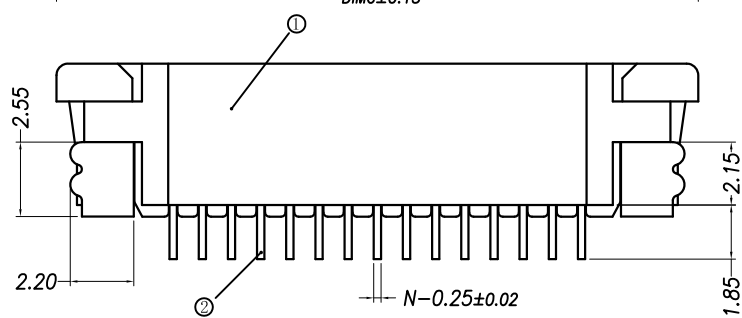
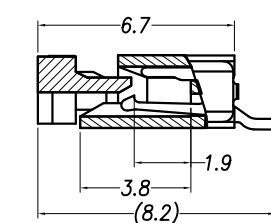
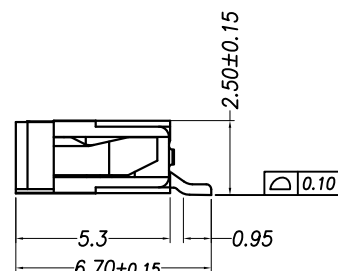
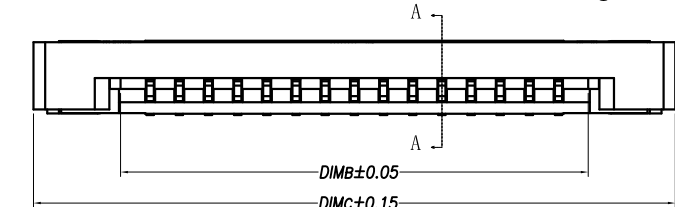
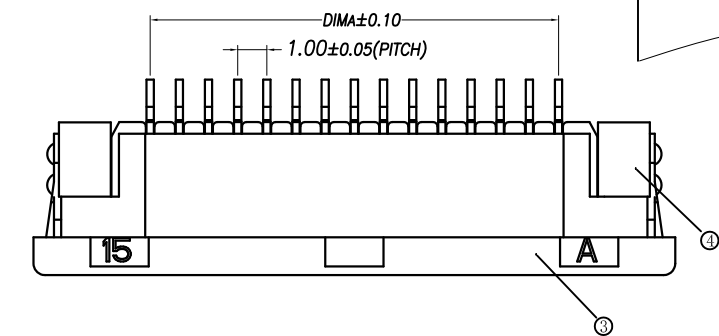
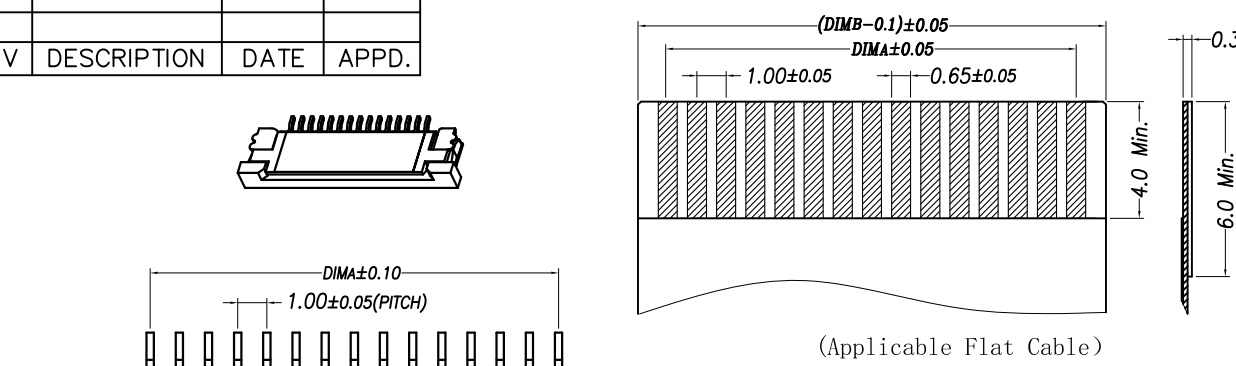

達立科技股份有限公司
Dawning Precision Co., Ltd.
 TEL: 886-2-82271388 FAX: 886-2-82272198

DESIGN	Jeff	SCALE	
DRAWING	Jeff	UNIT	mm
CHECK	Jeff	SIZE	A4: 210*297
APPROVAL	Honda	VERSION	01

TOLERANCE UNLESS OTHERWISE STATED(mm)	
0	±0.30
0.0	±0.20
0.00	±0.10
ANGLE	±2°

PART NAME	FPC 1.0mm PITCH SMT TYPE UNDER CONN.
PART NO	FP10252-XX0XN-S209
DRAWING NO	
DATE	2020/10/21