

△				
△				
△				
△				
ZONE	REV	DESCRIPTION	DATE	APPD.

R&D發行  
2019.07.16  
達立

**RoHS**  
**Compatible**

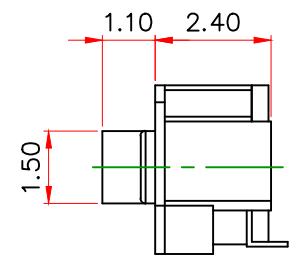
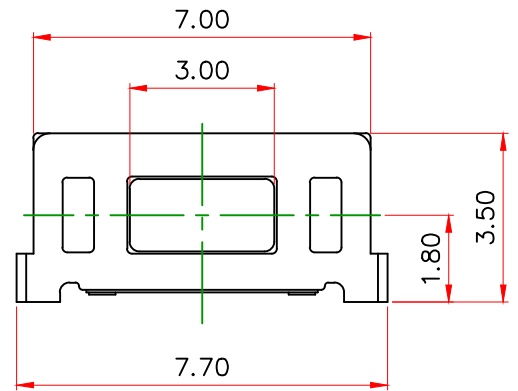

CIRCUIT DIAGRAM

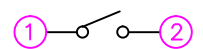

RECOMMENED P.C.B MOUNTING PATTERN DIMENSION

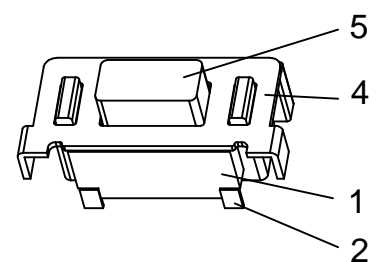
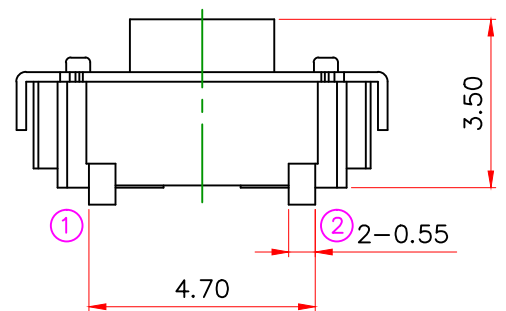
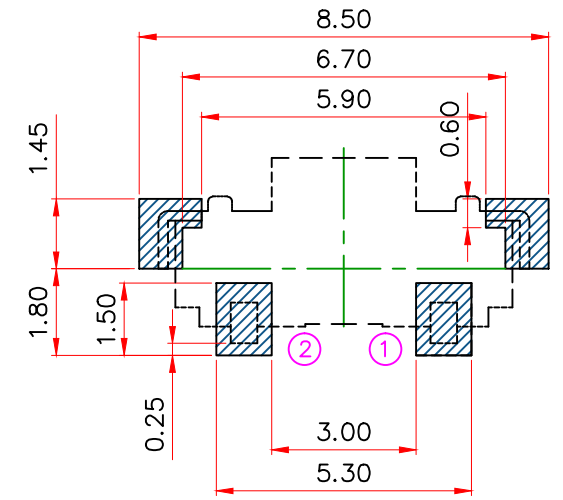

Specifications

1. Rating : DC 12V, 50mA.
2. Travel : 0.20±0.1mm
3. Contact resistance : 100mΩ Max.
4. Insulation resistance : 100MΩ Min.
5. Operating force : 160±50gf
6. Operating life : 50,000 cycles Min.

5	Stem	PPA	1	Black
4	Cover	Brass	1	Ag Plated
3	Contact	SUS	1	Ag Clad
2	Terminal	Brass	1	Ag Plated
1	Case	PA6T	1	White
No.	Part Name	Material	Q'ty	Finishing

**達立科技股份有限公司**  
**Dawning Precision Co., Ltd.**  
TEL: 886-2-82271388 FAX: 886-2-82272198

DESIGN	Jeff	SCALE	
DRAWING	Jeff	UNIT	mm
CHECK	Jeff	SIZE	A4: 210*297
APPROVAL	Honda	VERSION	04

TOLERANCE UNLESS OTHERWISE STATED(mm)	PART NAME	TACT SWITCH
0 ±0.35	PART NO	TS-A12-2-S085
0.0 ±0.30	DRAWING NO	
0.00 ±0.20	DATE	2019/07/16
ANGLE ±2°		