

▲				
▲				
▲				
▲				
ZONE	REV	DESCRIPTION	DATE	APPD.

發行
2013.03.15
達立

RoHS
Compatible

P.C.B Mounting
pattern Dimension

Circuit Diagram

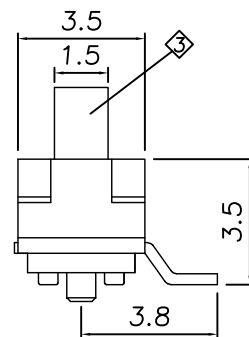
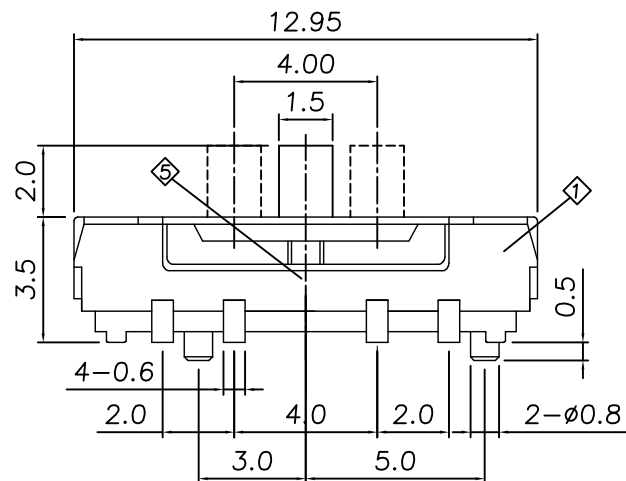
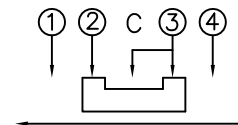
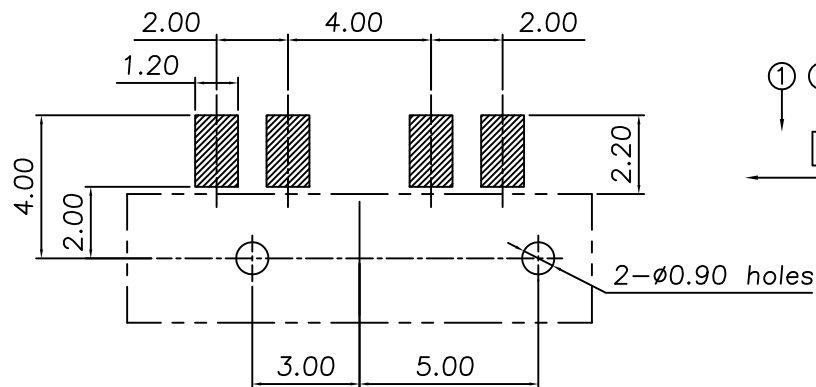
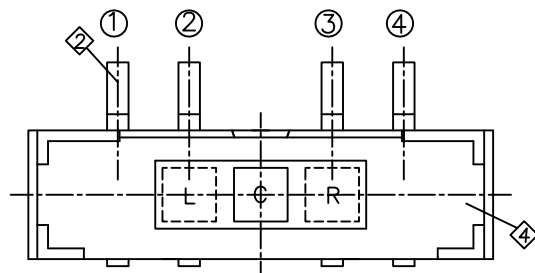

Specifications

1. Rating : DC 12V, 0.1A
2. Circuit : 1C-3P
3. Timing : non-shorting
4. Travel : 2.0±0.1 mm
5. Contact Resistance : 70mΩ Max.
6. Operating Life : 10,000 cycles
7. Operating force :

L→C←R 250±100gf
L←C→R 300±150gf

⑤	Clip	Phosphor Bronze	1	Ag Plate
④	Cover	Stainless Steel	1	
③	Knob	Nylon	1	UL 94 V-0
②	Terminal	Brass	1	Ag Plate
①	Case	Nylon	1	UL 94 V-0
NO	Part Name	Material	Q'ty	Finishing

達立科技股份有限公司



Dawning Precision Co., Ltd.

TEL: 886-2-82271388 FAX: 886-2-82272198

DESIGN	Frank	SCALE	
DRAWING	Frank	UNIT	mm
CHECK	Frank	SIZE	A4: 210*297
APPROVAL	Eric	VERSION	01

TOLERANCE UNLESS OTHERWISE STATED(mm)	
less than 10	±0.2
10~30	±0.3
30~100	±0.5
ANGIE	±2°

PART NAME	SLIDE SWITCH
PART NO	SS-C80T-S085
DRAWING NO	
DATE	2013/03/15