

Order information:
DP-B001S-XXH-X-S017

Package:
T: Tube
R: TAPE REEL

01~12 POLE

RD&發行
2023.11.24
達立

RoHS
Compatible

△				
△				
△				
△				
ZONE	REV	DESCRIPTION	DATE	APPD.

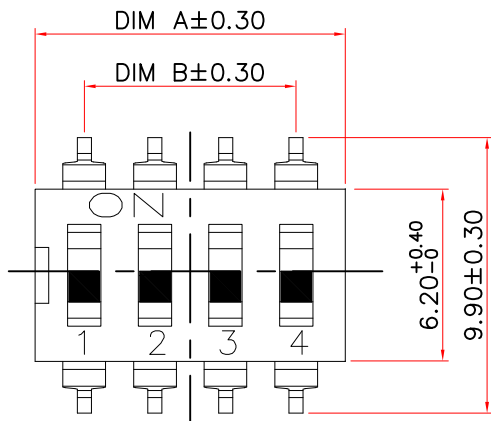

CIRCUIT DIAGRAM

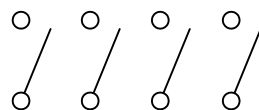

RECOMMENED P.C.B MOUNTING
PATTERN DIMENSION

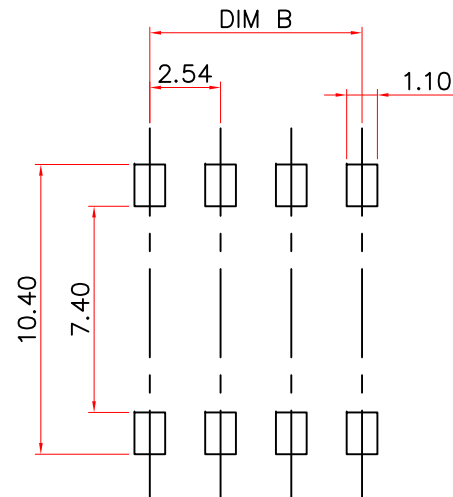

POLE	Dimensions	
	A	B
1	3.54	—
2	6.08	2.54
3	8.62	5.08
4	11.16	7.62
5	13.70	10.16
6	16.24	12.70
7	18.78	15.24
8	21.32	17.78
9	23.86	20.32
10	26.40	22.86
11	28.94	25.40
12	31.48	27.94

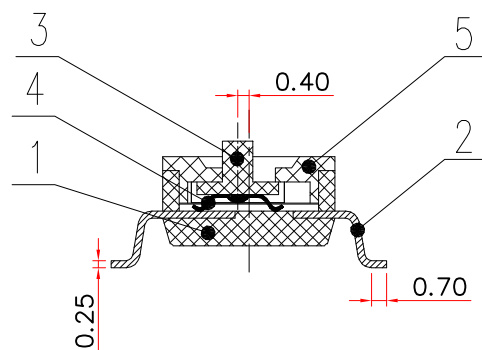
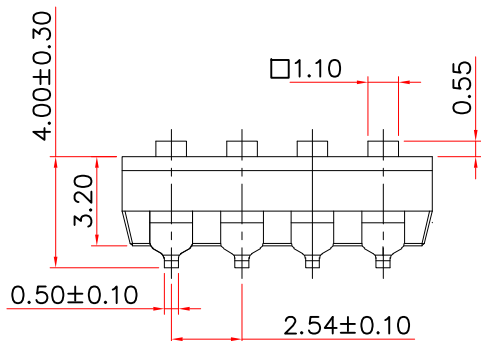

Specification

- Rating :
 - Non-Switching : 100mA, 50V DC
 - Switching : 25mA , 24V DC
- Contact resistance : 50mΩ Max(Initial).
- Insulation resistance : 100MΩ Min
- Operating force : 1Kgf Max.
- Operating life : 1,000 cycles Min.

No.	Part Name	Material	Q'ty	Finishing
5	Cover	PA9T/UL94 V-0	1	Black
4	Contact	Berylliu Copper	1	Au Plated
3	Actuator	PA46/UL94 V-0	1	White
2	Terminal	PBS	1	Au Plated
1	Case	PA9T/UL94 V-0	1	Black

達立科技股份有限公司

Dawning Precision Co.,Ltd.
TEL: 886-2-82271388 FAX: 886-2-82272198

DESIGN	Jeff	SCALE		
DRAWING	Jeff	UNIT	mm	
CHECK	Jeff	SIZE	A4: 210*297	
APPROVAL	Baker	VERSION	01	

TOLERANCE UNLESS OTHERWISE STATED(mm)	PART NAME	S.M.T. Type DIP SWITCH
0 — ±0.50	PART NO	DP-B001S-XXH-X-S017
0.0 — ±0.30	DRAWING NO	
0.00 — ±0.20	DATE	2023/11/23
ANGLE — ±2°		

www.dawning2.com.tw